



TITLE: 3PH DISTRIBUTION TRANSFORMER
NAMEPLATE INFORMATION

DES:	AOPPER
DATE:	25/06/17
SCALE:	NTS

SHEET 1 OF 2

EDB TX2A0045KBKF

0.1 httpd 2026/06/03 18:53

THIS DRAWING CONTAINS STRICTLY CONFIDENTIAL INFORMATION BELONGING TO HAMMOND POWER SOLUTIONS AND MUST NOT BE DISTRIBUTED OUTSIDE AUTHORIZED PARTIES.



hammond
POWER SOLUTIONS
595 Southgate Drive
Guelph, ON, N1G 3W6

CE II 3G
DEMKO 21 ATEX 2235X
IECEx UL 21.0116X
Ex ec IIC T3 Gc



HPS Titan™ X
Dry Type Encapsulated Transformer
Transformateur de Type Sec Encapsulé
Part No. TX2A0045KBKF

Cust. Ref. Ref. du Client	Serial No. No. de Serie	
Phase	HV/HT	480V 54.1A
Type	BIL	10 kV
Cooling Refroidissement	Term Bornes	H1 H2 H3
kVA	LV/BT	208Y/120V 125A
Temp. Rise Echauffement	BIL	10 kV
Temp Class Classe Temp	Term Bornes	X0 X1 X2 X3
Winding Enroulement	CU	-25° C ≤ Tamb ≤ +40° C
Frequency Hz	60	
Impedance % @ 135° C	2	
Encl. Type Type de Coffrage	IP66	
Weight lbs/kg Poids	640/291	

VOLTS	CURRENT COURANT	% RATED VOLTAGE % TENSION NOMINALE	CONNECTION EACH PHASE CONNECTION PAR PHASE
504	51.5	105	1
480	52.8	102.5	2
468	54.1	100	3
456	55.5	97.5	4
444	57.0	95	5
432	58.5	92.5	6
	60.1	90	7

HAZARDOUS LOCATIONS CLASS 1, ZONE 2
GROUP IIC, T3

SPACINGS BETWEEN ANY VENTILATED ENCLOSURE PANEL AND ANY ADJACENT WALL SHALL BE A MINIMUM OF 3 INCHES ELECTROSTATIC SHIELD

ABS TYPE APPROVAL CERTIFICATE NO. 21-2107547-PDA

WARNING / ATTENTION:
- EXPLOSION HAZARD. DO NOT DISCONNECT EQUIPMENT WHILE THE CIRCUIT IS LIVE OR UNLESS THE AREA IS FREE OF IGNITABLE CONCENTRATIONS.
- POTENTIAL ELECTROSTATIC CHARGING HAZARD. REFER TO THE INSTALLATION MANUAL.
- RISQUE D'EXPLOSION. NE PAS DERANCHER PENDANT QUE LE CIRCUIT EST SOUS TENSION OU A MOINS QUE L'EMPLACEMENT NE SOIT EXEMPT DE CONCENTRATIONS INFLAMMABLES.
- DANGER POTENTIEL DE CHARGE ELECTROSTATIQUE SE REFERER AU MANUEL D'INSTALLATION

SEISMIC QUALIFICATIONS:
OSP-0136/IBC 2018/ASCE 7-16
SDS ≤ 2.0g Z/h=1 Ip=1.5

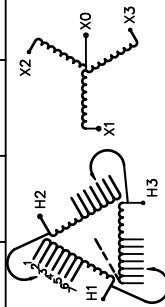

d000203bq

Made in Mexico

FRONT VIEW

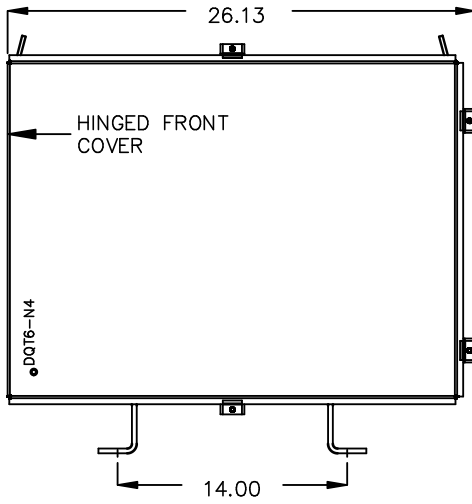

SIDE VIEW

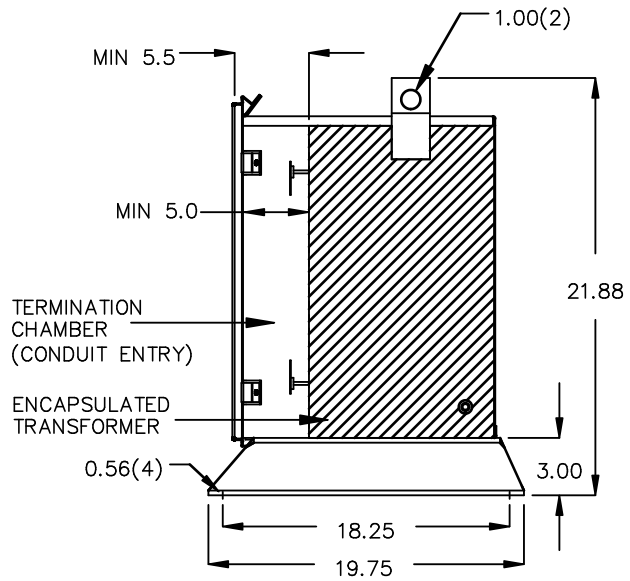

All Dimensions in inches

ENCLOSURE COLOR : ANSI 61 GREY – OUTDOOR

HV TERMINAL DETAIL

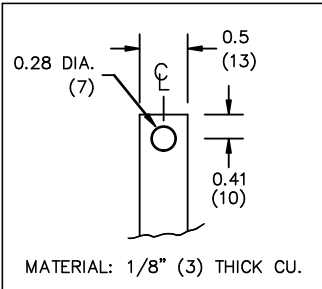

LV TERMINAL DETAIL

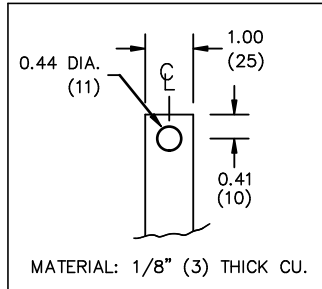

CUSTOMER NOTES:

- HV TERMINATED AT BOTTOM FRONT
- LV TERMINATED AT TOP FRONT



TITLE: 3PH DISTRIBUTION TRANSFORMER

DES:	AOPPER
DATE:	25/06/17
SCALE:	NTS

NO.	DATE	BY	REVISION

SHEET 2 OF 2

EDB TX2A0045KBF