



TITLE: 3PH DISTRIBUTION TRANSFORMER  
NAMEPLATE INFORMATION

NO.	DATE	BY	REVISION	SCALE:
2	21/07/16	PP	EDB UPDATE	DES: PPICASSI
1	20/03/17	PP	SEISMIC UPDATE	DATE: 19/07/29
				SCALE: NTS

SHEET 1 OF 2

EDB TN2D0030KDKF

2.0 httpd 2026/06/24 21:49

THIS DRAWING CONTAINS STRICTLY CONFIDENTIAL INFORMATION BELONGING TO HAMMOND POWER SOLUTIONS AND MUST NOT BE DISTRIBUTED OUTSIDE AUTHORIZED PARTIES.



**POWER SOLUTIONS**  
Guelph, ONT  
Compton, CA

**HPS Titan™ N**  
Dry Type Encapsulated Transformer  
Transformateur de Type Sec Encapsulé



UL LISTED  
31GW E258346  
GENERAL PURPOSE  
TRANSFORMER FOR USE IN  
HAZARDOUS LOCATIONS

Part No. **TN2D0030KDKF**

Serial No. [ ]  
No. de Serie [ ]

HV/HT 480V  
BIL 36.1A

Term Bornes 10 kV  
LV/BT H1 H2 H3

BIL 72.2A  
Term Bornes 10 kV

X1 X2 X3

Cust. Ref. [ ]  
Ref. du Client [ ]

Phase 3

Type HZQT

Cooling Refroidissement ANC

kVA 30

Temp. Rise Echauffement 115 °C

Temp Class Classe Temp 180 °C

Winding Enroulement CU

Frequency Hz 60

Impedance % @ 135 °C 2

Encl. Type Type de Coffrage 4

Weight Poids lbs 470

HAZARDOUS LOCATIONS CLASS 1, DIV 2  
GROUPS A, B, C & D  
TEMPERATURE CODE: T3A

HAZARDOUS LOCATIONS CLASS 1, ZONE 2  
GROUPS IIC, T3  
SPACINGS BETWEEN ANY VENTILATED ENCLOSURE PANEL AND  
ANY ADJACENT WALL SHALL BE A MINIMUM OF 3 INCHES  
ELECTROSTATIC SHIELD

VOLTS	CURRENT COURANT	% RATED VOLTAGE % TENSION NOMINALE	CONNECTION EACH PHASE CONNECTION PAR PHASE
504	34.4	105	1
480	35.2	102.5	2
468	36.1	100	3
456	37.0	97.5	4
444	38.0	95	5
432	39.0	92.5	6
	40.1	90	7

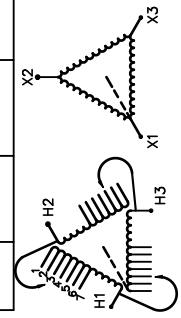

WARNING - EXPLOSION HAZARD. DO NOT DISCONNECT EQUIPMENT WHILE THE CIRCUIT IS LIVE OR UNLESS THE AREA IS FREE OF IGNITABLE CONCENTRATIONS.  
AVERTISSEMENT : RISQUE D'EXPLOSION. NE PAS D BRANCHER PENDANT QUE LE CIRCUIT EST SOUS TENSION OU MONS QUE L'EMPLACEMENT NE SOIT EXEMPT DE CONCENTRATIONS INFLAMMABLES.

SEISMIC QUALIFICATIONS:  
OSP=0136/IBC 201B/ASCE 7-16  
SDS<=2.0g Z/h=1 p=1.5

d000200bq

FRONT VIEW

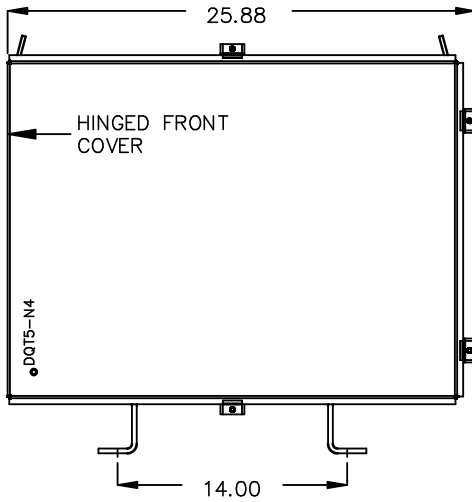

SIDE VIEW

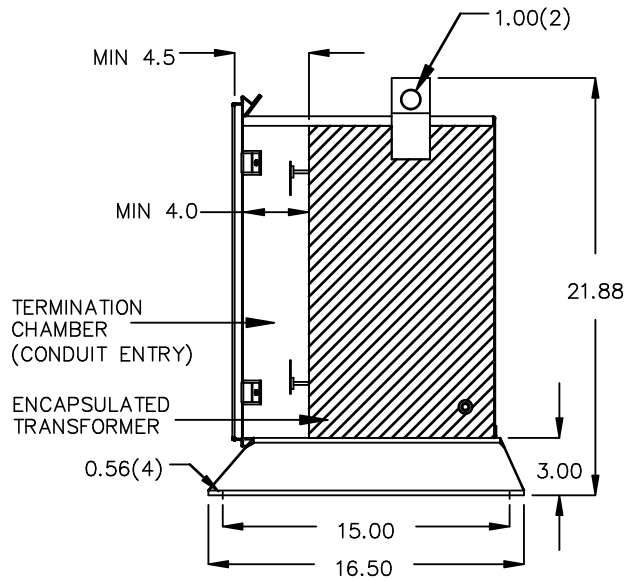

All Dimensions in inches

ENCLOSURE COLOR : ANSI 61 GREY – OUTDOOR

HV TERMINAL DETAIL

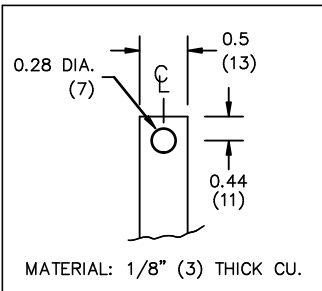

LV TERMINAL DETAIL

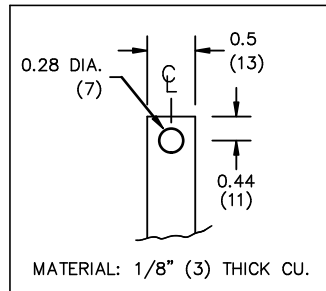

CUSTOMER NOTES:

- HV TERMINATED AT BOTTOM FRONT
- LV TERMINATED AT TOP FRONT



TITLE: 3PH DISTRIBUTION TRANSFORMER

2	21/07/16	PP	EDB UPDATE	DES: PPLICASSI
1	20/03/17	PP	SEISMIC UPDATE	DATE: 19/07/29
NO.	DATE	BY	REVISION	SCALE: NTS

SHEET 2 OF 2

EDB TN2D00030KDKF