



TITLE: 3PH DISTRIBUTION TRANSFORMER
NAMEPLATE INFORMATION

DES:	PPICASSI
DATE:	23/04/27
SCALE:	NTS

SHEET 1 OF 2

EJB TN2A0030KHKE

0.0 httpd 2026/04/04 08:52

THIS DRAWING CONTAINS STRICTLY CONFIDENTIAL INFORMATION BELONGING TO HAMMOND POWER SOLUTIONS AND MUST NOT BE DISTRIBUTED OUTSIDE AUTHORIZED PARTIES.

POWER SOLUTIONS
Guelph, ONT Compton, CA Baraboo, WI
Monterrey, MX

HPS Titan™ N
Dry Type Encapsulated Transformer
Transformateur de Type Sec Encapsulé

UL US LISTED
31GW E258346
GENERAL PURPOSE TRANSFORMER FOR USE IN HAZARDOUS LOCATIONS
BUILT TO ABS STANDARD

Cust. Ref. [] Serial No. []
Ref. du Client [] No. de Serie []

Phase 3 HV/HT 480V 36.1A

Type HZQT BIL 10 kV

Cooling ANC Term Bornes H1 H2 H3

kVA 30 LV/BT 400Y/231V 43.3A

Temp. Rise 115 °C BIL 10 kV

Temp Class 180 °C Term Bornes X0 X1 X2 X3

Winding CU

Frequency 60

Impedance % 2.1

Encl. Type 4

Weight lbs/kg 480/218

VOLTS	CURRENT COURANT	% RATED VOLTAGE % TENSION NOMINALE	CONNECTION EACH PHASE CONNECTION PAR PHASE	HAZARDOUS LOCATIONS CLASS 1, DIV 2 GROUPS A, B, C & D TEMPERATURE CODE: T3A
504	34.4	105	1	HAZARDOUS LOCATIONS CLASS 1, ZONE 2 GROUPS IIC, T3
480	35.2	102.5	2	SPACINGS BETWEEN ANY VENTILATED ENCLOSURE PANEL AND ANY ADJACENT WALL SHALL BE A MINIMUM OF 3 INCHES ELECTROSTATIC SHIELD
468	36.1	100	3	
456	37.0	97.5	4	
444	38.0	95	5	
432	39.0	92.5	6	
	40.1	90	7	

WARNING - EXPLOSION HAZARD. DO NOT DISCONNECT EQUIPMENT WHILE THE CIRCUIT IS LIVE OR UNLESS THE AREA IS FREE OF IGNITABLE CONCENTRATIONS.
AVERTISSEMENT : RISQUE D'EXPLOSION. NE PAS DÉBRANCHER PENDANT QUE LE CIRCUIT EST SOUS TENSION OU A MOINS QUE L'EMPLACEMENT NE SOIT EXEMPT DE CONCENTRATIONS INFLAMMABLES.

SEISMIC QUALIFICATIONS:
OSP=0136/IBC 201B/ASCE 7-16
SDS<=2.0g Z/h=1 p=1.5

d000200bq

FRONT VIEW

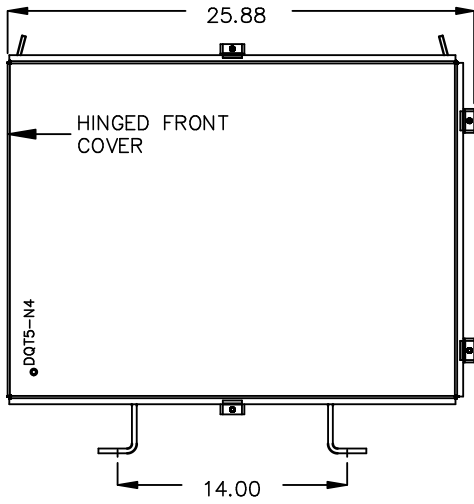

SIDE VIEW

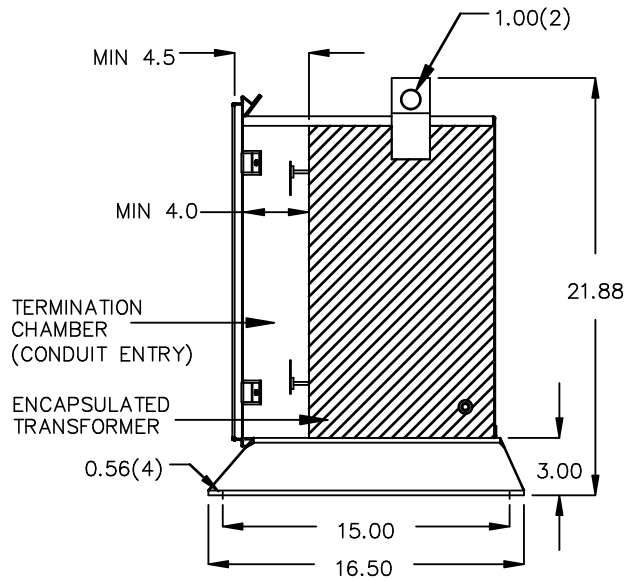

All Dimensions in inches

ENCLOSURE COLOR : ANSI 61 GREY – OUTDOOR

HV TERMINAL DETAIL

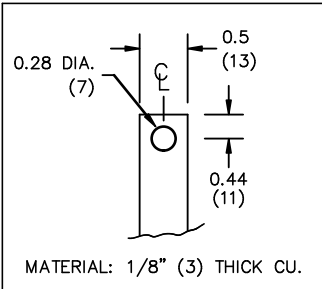

LV TERMINAL DETAIL

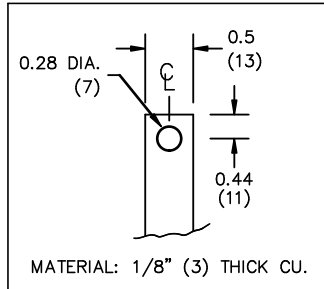

CUSTOMER NOTES:

- HV TERMINATED AT BOTTOM FRONT
- LV TERMINATED AT TOP FRONT



TITLE: 3PH DISTRIBUTION TRANSFORMER

DES:	PPICASSI
DATE:	23/04/27
SCALE:	NTS

NO.	DATE	BY	REVISION

SHEET 2 OF 2

EDB TN2A0030KHKF