

All Dimensions in inches

ENCLOSURE COLOR :ANSI 61 GREY – OUTDOOR

HV TERMINAL DETAIL

LV TERMINAL DETAIL

X0 TERMINAL DETAIL

MECHANICAL TYPE LUGS INCLUDED
SUITABLE FOR 600MCM-2 CU/AL
CONDUCTORS
1 CONDUCTOR PER PHASE

MECHANICAL TYPE LUGS INCLUDED
SUITABLE FOR 350MCM-6 CU/AL
CONDUCTORS
2 CONDUCTORS PER PHASE

MECHANICAL TYPE LUGS INCLUDED
SUITABLE FOR 600MCM-2 CU/AL
CONDUCTORS
1 CONDUCTOR PER PHASE

CUSTOMER NOTES:

- HV TERMINATED AT TOP FRONT
- LV TERMINATED AT BOTTOM FRONT
- X0 TERMINATED AT BOTTOM FRONT
- 200% RATED NEUTRAL X0 HAS QTY 2 LUGS



TITLE: 3PH DISTRIBUTION TRANSFORMER

DES:	RMOVVA		
DATE:	23/09/14		
SCALE:	NTS		
NO.	DATE	BY	REVISION

SHEET 2 OF 3

EDBSK3A0225PK9S

ENCLOSURE BOTTOM VIEW

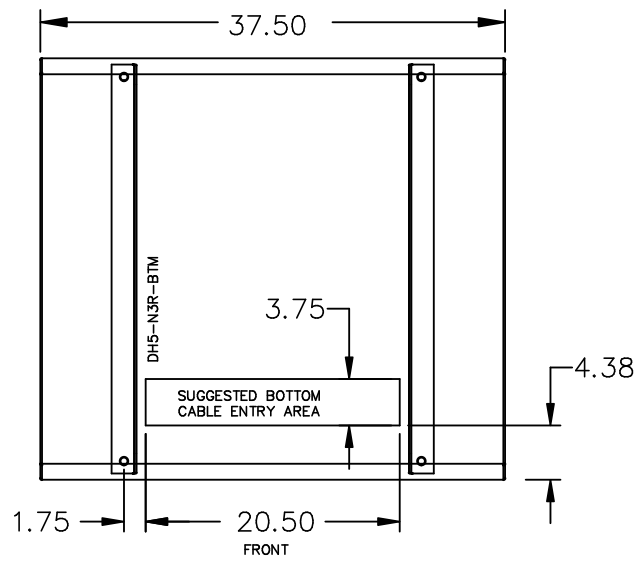

NOTE:
 WHEN BOTTOM CABLE ENTRY IS OPTED, THE SPACE USED FOR CONDUITS IN THE FRONT OF THE TRANSFORMER SHOULD NOT OBSTRUCT MORE THAN 50% OF THE FRONT AIR INTAKE AREA DEFINED BETWEEN THE BOTTOM PLATE AND THE SUPPORTING LEGS.
 SEE MANUAL FOR ADDITIONAL INFORMATION



TITLE: 3PH DISTRIBUTION TRANSFORMER
 ENCLOSURE BOTTOM VIEW

				DES: RMOVVA
				DATE: 23/09/14
NO.	DATE	BY	REVISION	SCALE: NTS

SHEET 3 OF 3

EDBSK3A0225PK9S