



TITLE: 3PH DISTRIBUTION TRANSFORMER
NAMEPLATE INFORMATION

1	21/07/16	PP	EDB UPDATE	DES: DCORTEZ
NO.	DATE	BY	REVISION	SCALE: NTS

SHEET 1 OF 3

EDBMG3A0500SPSCHCO

1:1 httpd 2026/06/21 21:06

THIS DRAWING CONTAINS STRICTLY CONFIDENTIAL INFORMATION BELONGING TO HAMMOND POWER SOLUTIONS AND MUST NOT BE DISTRIBUTED OUTSIDE AUTHORIZED PARTIES.



hammond
POWER SOLUTIONS

Distribution Transformer
Transformateur de Distribution

LR 3902
DISTRIBUTION TRANSFORMER
E147879

Hyderabad, IN Guelph, ONT Baraboo, WI 8 03423 13574 4
Compton, CA Monterrey, MX Part No. MG3A0500SPSCHCO

Cust. Ref. [] Serial No. []
Ref. du Client No. de Serie

Phase	3	HV/HT	4160V	69.4A
Type	K	BIL	30 kV	
Cooling Refroidissement	ANN	Term Bornes	H1 H2 H3	
kVA	500	LV/BT	600Y/346V	481A
Temp. Rise Echauffement	150 °C	BIL	10 kV	
Temp Class Classe Temp	220 °C	Term Bornes	X0 X1 X2 X3	
Winding Enroulement	CU	Energy Regulations Règlements Energetique	DOE 10 CFR PART 431:2016	
Frequency Fréquence Hz	60	CEE ACT SOR/2018-201		
Impedance % @ 170 °C	4.2			
End. Type/Category Type ou catégorie de boîtier	3R	C		
Weight Poids	3050	lbs		

VOLTS	CURRENT COURANT	% RATED VOLTAGE % NOMINALE	CONNECTION CONNECTION PAR PHASE
4368	66.1	105	1-2
4264	67.7	102.5	2-3
4160	69.4	100	3-4
4056	71.2	97.5	4-5
3952	73.0	95	5-6

SPACINGS BETWEEN ANY VENTILATED ENCLOSURE PANEL AND ANY ADJACENT WALL SHALL BE A MINIMUM OF 12 INCHES

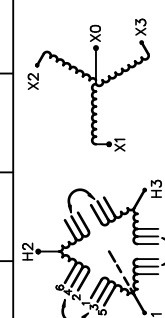

SEISMIC QUALIFICATIONS:
AS FLOOR MOUNT ONLY
IBC 2018/ASCE 7-16
SDS<=2.0g Z/n=0 Ip=1.5

d000590hb

FRONT VIEW

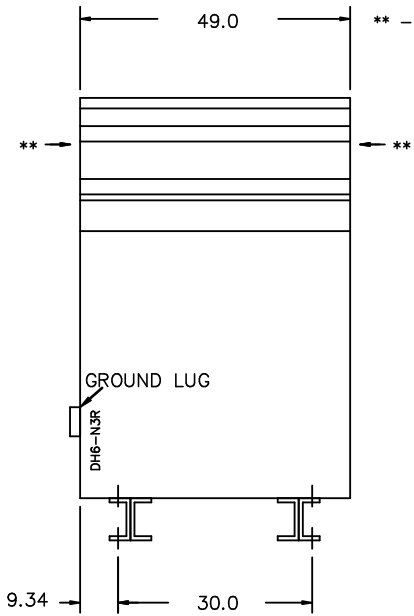

** - Recommended cable entry locations only
cutouts & gland plates not provided.

SIDE VIEW

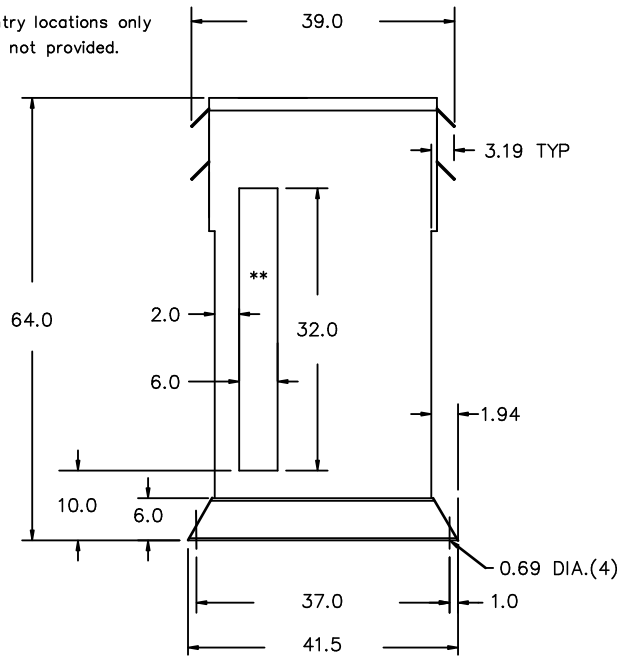

All Dimensions in inches

ENCLOSURE COLOR : ANSI 61 GREY - OUTDOOR

HV TERMINAL DETAIL

LV TERMINAL DETAIL

MECHANICAL TYPE LUGS INCLUDED
SUITABLE FOR #2/0-14 CU/AL
CONDUCTORS
1 CONDUCTOR PER PHASE

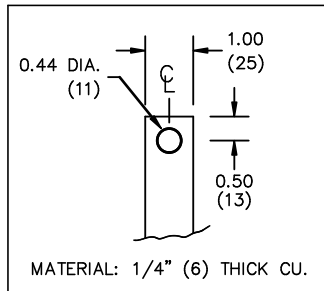

CUSTOMER NOTES:

- HV TERMINATED AT TOP FRONT
- LV TERMINATED AT BOTTOM FRONT

THIS DRAWING CONTAINS STRICTLY CONFIDENTIAL INFORMATION BELONGING TO HAMMOND POWER SOLUTIONS AND MUST NOT BE DISTRIBUTED OUTSIDE AUTHORIZED PARTIES.



TITLE: 3PH DISTRIBUTION TRANSFORMER

1	21/07/16	PP	EDB UPDATE	DES: DCORTEZ
NO.	DATE	BY	REVISION	SCALE: NTS

SHEET 2 OF 3

EDBMC3A0500SPSCHCO

1.1 http://2026/06/21 21:06

ENCLOSURE BOTTOM VIEW



NOTE:
 WHEN BOTTOM CABLE ENTRY IS OPTED, THE SPACE USED FOR CONDUITS IN THE FRONT OF THE TRANSFORMER SHOULD NOT OBSTRUCT MORE THAN 50% OF THE FRONT AIR INTAKE AREA DEFINED BETWEEN THE BOTTOM PLATE AND THE SUPPORTING LEGS.
 SEE MANUAL FOR ADDITIONAL INFORMATION



TITLE: 3PH DISTRIBUTION TRANSFORMER
 ENCLOSURE BOTTOM VIEW

1	21/07/16	PP	EDB UPDATE	DES: DCORTEZ
NO.	DATE	BY	REVISION	SCALE: NTS

SHEET 3 OF 3

EDBMC3A0500SPSCHCO