



TITLE: 3PH DISTRIBUTION TRANSFORMER
NAMEPLATE INFORMATION

3	21/07/16	PP	EDB UPDATE	DES: DCORTEZ
2	21/04/06	DC	UPDATED TOTAL WEIGHT(HCN: 74439)	DATE: 17/07/28
NO.	DATE	BY	REVISION	SCALE: NTS

SHEET 1 OF 3

EDBMG3A0300RKS/AHCO

3.0 httpd 2026/04/03 14:45

THIS DRAWING CONTAINS STRICTLY CONFIDENTIAL INFORMATION BELONGING TO HAMMOND POWER SOLUTIONS AND MUST NOT BE DISTRIBUTED OUTSIDE AUTHORIZED PARTIES.

hammond
POWER SOLUTIONS

Distribution Transformer
Transformateur de Distribution

LR 3902
DISTRIBUTION TRANSFORMER
E147879

8 03423 13370 2

ALSO VERIFIED IN ACCORDANCE TO ENERGY STANDARD C802.2-18 BY UNDERWRIERS LABORATORIES INC. 316

LISTED

Hyderabad, IN Guelph, ONT Baraboo, WI Spangings BETWEEN ANY VENTILATED ENCLOSURE PANEL AND ANY ADJACENT WALL SHALL BE A MINIMUM OF 5 INCHES EXCEPT WHEN WALL MOUNTED USING APPROVED WALL MOUNT

Compton, CA Monterrey, MX Part No. MG3A0300RKS/AHCO

Cust. Ref. Ref. du Client	Serial No. No. de Serie	VOLTS	CURRENT COURANT	% RATED VOLTAGE % NOMINALE	CONNECTION THE CONNECTION PAR PHASE
3	HV/HT	2400V	68.7	105	1-2
K	BIL	20 kV	70.4	102.5	2-3
ANN	Term Bornes	H1 H2 H3	72.2	100	3-4
300	LV/BT	480Y/277V	74.0	97.5	4-5
150 °C	BIL	10 kV	76.0	95	5-6
220 °C	Term Bornes	X0 X1 X2 X3			
AL	Energy Regulations	DOE 10 CFR PART 431:2016			
60	Reglements de Energetique	CEE ACT SOR/2018-201			
170 °C	Impedance %				
3R C	End. Type/Category Type ou categorie de boitier				
2050	Weight Poids				

SEISMIC QUALIFICATIONS:
AS FLOOR MOUNT ONLY
IBC 2018/ASCE 7-16
SDS<=2.0g Z/n=0 Ip=1.5

d000590hb

FRONT VIEW



** - Recommended cable entry locations only
cutouts & gland plates not provided.

SIDE VIEW



All Dimensions in inches

ENCLOSURE COLOR : ANSI 61 GREY - OUTDOOR

HV TERMINAL DETAIL

LV TERMINAL DETAIL

MECHANICAL TYPE LUGS INCLUDED
SUITABLE FOR #2/0-14 CU/AL
CONDUCTORS
1 CONDUCTOR PER PHASE

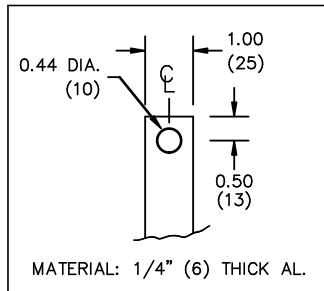

CUSTOMER NOTES:

- HV TERMINATED AT TOP FRONT
- LV TERMINATED AT BOTTOM FRONT

THIS DRAWING CONTAINS STRICTLY CONFIDENTIAL INFORMATION BELONGING TO HAMMOND POWER SOLUTIONS AND MUST NOT BE DISTRIBUTED OUTSIDE AUTHORIZED PARTIES.



TITLE: 3PH DISTRIBUTION TRANSFORMER

3	21/07/16	PP	EDB UPDATE	DES: DCORTEZ
2	21/04/06	DC	UPDATED TOTAL WEIGHT(HCN: 74439)	DATE: 17/07/28
NO.	DATE	BY	REVISION	SCALE: NTS

SHEET 2 OF 3

EDBMC3A0300RKS/H/CO

3.0 httpd 2026/04/03 14:45

ENCLOSURE BOTTOM VIEW

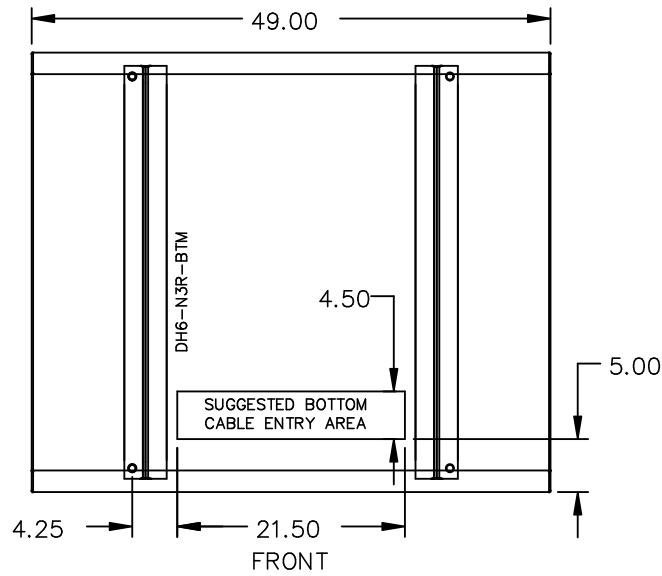

NOTE:
 WHEN BOTTOM CABLE ENTRY IS OPTED, THE SPACE USED FOR CONDUITS IN THE FRONT OF THE TRANSFORMER SHOULD NOT OBSTRUCT MORE THAN 50% OF THE FRONT AIR INTAKE AREA DEFINED BETWEEN THE BOTTOM PLATE AND THE SUPPORTING LEGS.
 SEE MANUAL FOR ADDITIONAL INFORMATION



TITLE: 3PH DISTRIBUTION TRANSFORMER
 ENCLOSURE BOTTOM VIEW

3	21/07/16	PP	EDB UPDATE	DES: DCORTEZ
2	21/04/06	DC	UPDATED TOTAL WEIGHT(HCN: 74439)	DATE: 17/07/28
NO.	DATE	BY	REVISION	SCALE: NTS

SHEET 3 OF 3

EDBMC3A0300RKS/SHCO