



TITLE: 3PH DISTRIBUTION TRANSFORMER
NAMEPLATE INFORMATION

1	21/07/13	PP	EDB UPDATE	DES: RMOVVA
NO.	DATE	BY	REVISION	SCALE: NTS

SHEET 1 OF 3

EDBMG3A0045SBSAGCO

1.0 httpd 2026/06/03 10:29

THIS DRAWING CONTAINS STRICTLY CONFIDENTIAL INFORMATION BELONGING TO HAMMOND POWER SOLUTIONS AND MUST NOT BE DISTRIBUTED OUTSIDE AUTHORIZED PARTIES.

hammond
POWER SOLUTIONS

Distribution Transformer
Transformateur de Distribution

LR 3902
DISTRIBUTION TRANSFORMER
E147879
LISTED

Hyderabad, IN Guelph, ONT Baraboo, WI
Compton, CA Monterrey, MX

Part No. MG3A0045SBSAGCO

ALSO VERIFIED IN ACCORDANCE
TO ENERGY STANDARD C802.2-18
BY UNDERWRIERS LABORATORIES INC. © 316

Cust. Ref. Ref. du Client	Serial No. No. de Serie	HV/HT	4160V	6.2A	
Phase	3	BIL	30 kV		
Type	K	Term Bornes	H1 H2 H3		
Cooling Refroidissement	ANN	LV/BT	208Y/120V	125A	
kVA	45	BIL	10 kV		
Temp. Rise Echauffement	130 °C	Term Bornes	X0 X1 X2 X3		
Temp Class Classe Temp	200 °C	Winding Enroulement	CU/AL	Energy Regulations DOE 10 CFR PART 431:2016	
Frequency	60	Frequency Hz	60	Reglements de Energetique CEE ACT SOR/2018-201	
Impedance % @ 150 °C	3.9	End. Type/Category Type ou categorie de boitier	3R C		
Weight Poids	520				

SPACINGS BETWEEN ANY VENTILATED ENCLOSURE PANEL AND ANY ADJACENT WALL SHALL BE A MINIMUM OF 3 INCHES
ESPACEMENTS ENTRE LES PANNEAUX DE BOUTIER VENTILE ET LES MURS ADJACENT DOIVENT ETRE UN MINIMUM DE 3 POUNCES

VOLTS	CURRENT COURANT	% RATED VOLTAGE % NOMINALE	CONNECTION THE CONNECTION PAR PHASE
4368	5.9	105	1-2
4264	6.1	102.5	2-3
4160	6.2	100	3-4
4056	6.4	97.5	4-5
3952	6.6	95	5-6

SEISMIC QUALIFICATIONS:
AS FLOOR MOUNT ONLY
IBC 2018/ASCE 7-16
SDS<=2.0g Z/n=1 Ip=1.5

d000590hb

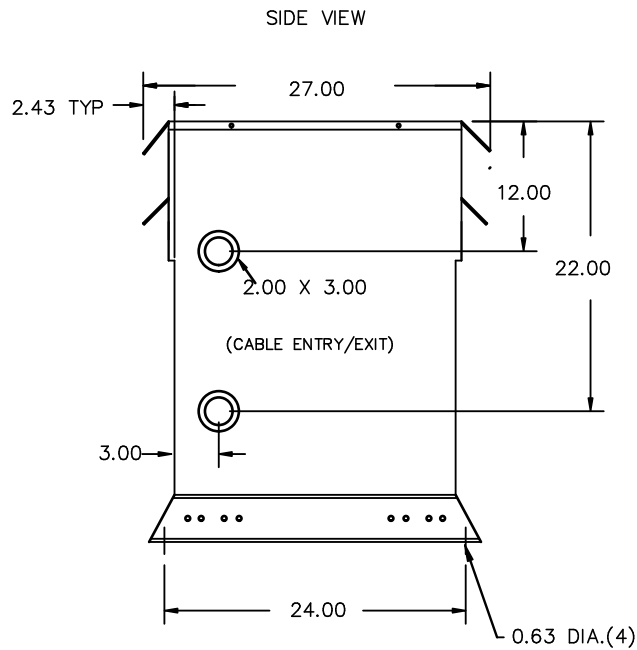
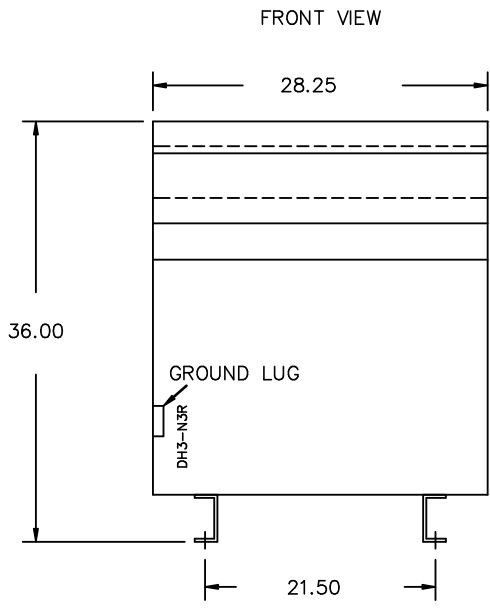

All Dimensions in inches

ENCLOSURE COLOR :ANSI 61 GREY – OUTDOOR

HV TERMINAL DETAIL

LV TERMINAL DETAIL

MECHANICAL TYPE LUGS INCLUDED
SUITABLE FOR #14-2 CU/AL
CONDUCTORS
1 CONDUCTOR PER PHASE

MECHANICAL TYPE LUGS INCLUDED
SUITABLE FOR 250MCM-6 CU/AL
CONDUCTORS
1 CONDUCTOR PER PHASE

CUSTOMER NOTES:

- HV TERMINATED AT TOP FRONT
- LV TERMINATED AT BOTTOM FRONT



TITLE: 3PH DISTRIBUTION TRANSFORMER

1	21/07/13	PP	EDB UPDATE	DES: RMOVVA
NO.	DATE	BY	REVISION	SCALE: NTS

SHEET 2 OF 3

EDBMC340045SBSACCO

1.0 httpd 2026/06/03 10:29

ENCLOSURE BOTTOM VIEW



NOTE:
 WHEN BOTTOM CABLE ENTRY IS OPTED, THE SPACE USED FOR CONDUITS IN THE FRONT OF THE TRANSFORMER SHOULD NOT OBSTRUCT MORE THAN 50% OF THE FRONT AIR INTAKE AREA DEFINED BETWEEN THE BOTTOM PLATE AND THE SUPPORTING LEGS.
 SEE MANUAL FOR ADDITIONAL INFORMATION



TITLE: 3PH DISTRIBUTION TRANSFORMER
 ENCLOSURE BOTTOM VIEW

1	21/07/13	PP	EDB UPDATE	DES: RMOVVA
NO.	DATE	BY	REVISION	SCALE: NTS

SHEET 3 OF 3

EDBMC3A0045SBSAGCO