



® LR 3902

UL DRY TYPE TRANSFORMER 77JUS E112313

LISTED

GUELPH, ONT. BARABOO, WI COMPTON, CA MONTERREY, MX

THREE PHASE DRY TYPE DRIVE ISOLATION TRANSFORMER
TRANSFORMATEUR TRIPHASE POUR VARIATEUR DE VITESSE DE MOTEURS

HV/HT	480V			Cust. Ref. Réf. du client	
BIL	-			Serial No. No. de série	
TERM. BORNES	H1 H2 H3			Part No. No. de pièce	DM440KK
	VOLTS	CURRENT COURANT	% RATED VOLTAGE % TENSION NOMINALE	CONNECTION EACH PHASE CONNEXION PAR PHASE	kVA
	504	504	105	1-2	440
	492	516	102.5	2-3	TYPE
	480	529	100	3-4	K
	468	543	97.5	4-5	Cooling Refroidissement
	456	557	95	5-6	ANN
					Temp. Rise Echauffement
					150 °C
					Temp. Class Classe de Temp.
					220 °C
					Frequency Fréquence
					60 Hz
					Impédance % @ 170 °C
					5.3
LV/BT	480Y/277V			Encl. Type Type de boîtier	3R
BIL	-			Wt Poids	2600
TERM. BORNES	X0 X1 X2 X3			Winding Enroulement	AL

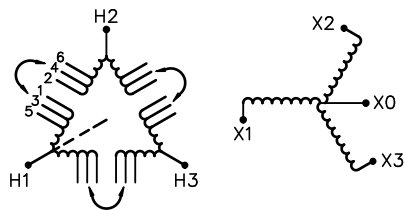

SPACINGS BETWEEN ANY VENTILATED ENCLOSURE PANEL AND ANY ADJACENT WALL SHALL BE A MINIMUM OF 8.25 INCHES

4003102b



TITLE: 3PH DRIVE TRANSFORMER
NAMEPLATE INFORMATION

1	21/07/16	PP	EDB UPDATE	DES: LCEN
NO.	DATE	BY	REVISION	SCALE: NTS

SHEET 1 OF 2

EDBDM440KK

1.0 http://www.hammond.com/2026/05/04/10-03

THIS DRAWING CONTAINS STRICTLY CONFIDENTIAL INFORMATION BELONGING TO HAMMOND POWER SOLUTIONS AND MUST NOT BE DISTRIBUTED OUTSIDE AUTHORIZED PARTIES.

FRONT VIEW

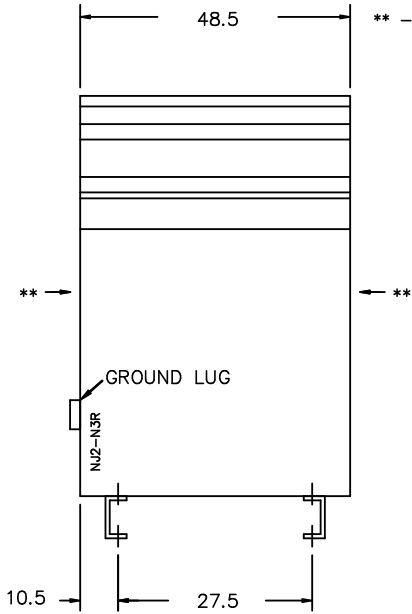

** - Recommended cable entry locations only
cutouts & gland plates not provided.

SIDE VIEW

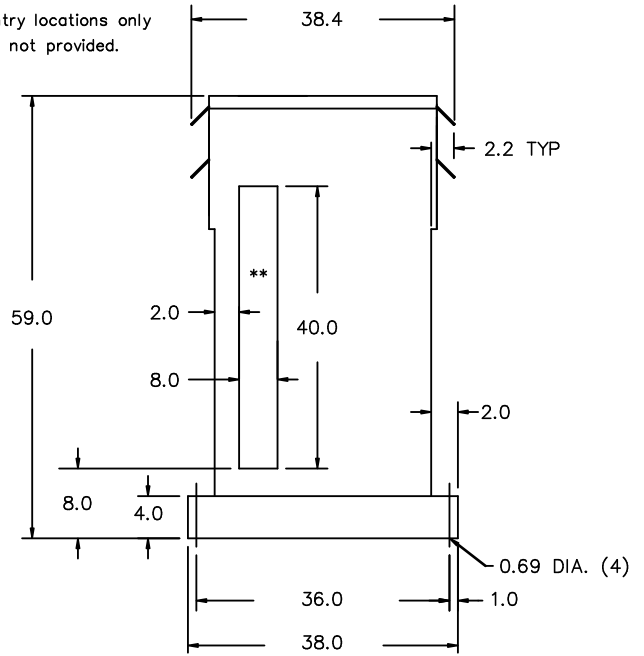

All Dimensions in inches

ENCLOSURE COLOR : ANSI 61 GREY - OUTDOOR

HV TERMINAL DETAIL

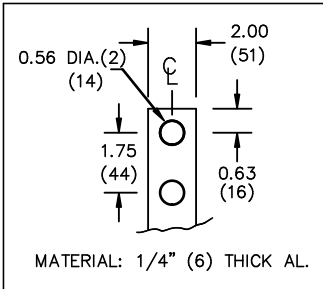

LV TERMINAL DETAIL

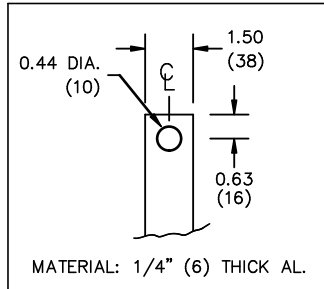

CUSTOMER NOTES:

- HV TERMINATED AT TOP FRONT
- LV TERMINATED AT BOTTOM FRONT
- C/W 1-"NC"- THERMOSTAT PER COIL CONNECTED TO T.B.



TITLE: 3PH DRIVE TRANSFORMER

1	21/07/16	PP	EDB UPDATE	DES: LCEN
NO.	DATE	BY	REVISION	SCALE: NTS

SHEET 2 OF 2

EDBDM440KK