

FRONT VIEW

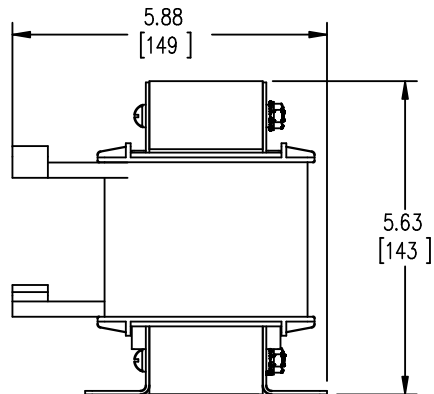

SIDE VIEW

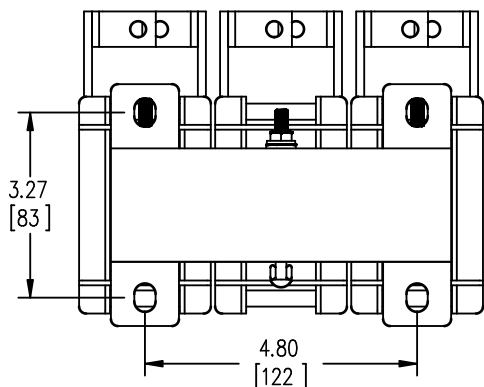

BOTTOM VIEW

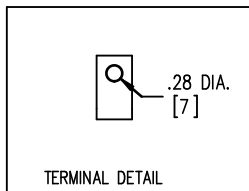

TERMINAL DETAIL

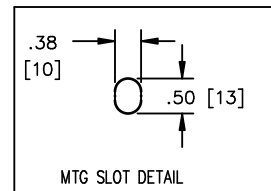

MTG SLOT DETAIL



TOLERANCES
MOUNTING CENTERS = +/- .06"
MOUNTING HOLE SIZE = +/- .005"

THIS DRAWING CONTAINS PROPRIETARY INFORMATION
BELONGING TO HAMMOND POWER SOLUTIONS INC.,
AND IS NOT FOR GENERAL DISTRIBUTION

All Dimensions in Inches
mm in Parenthesis

REACTOR

hammond
POWER SOLUTIONS

HPS CENTURION R
3PH DRY TYPE
REACTOR

MADE IN CANADA P/N CRX0075AC

INDUCT. .12 mH Hz 50/60 AMPS 75 IP00

0.6 kV CLASS TEMP CLASS 180°C TYPE JR-2

WEIGHT 17 (LBS/KG) AMBIENT: 50°C

USE WITH SUITABLY RATED LISTED (ZMVV) LUGS

WINDING TERMINAL TEMPERATURE: 75° C



LR3902



IND. CONT. EQ. E61431 LISTED

f0037760e

NOTES:



TITLE: 3 PHASE LINE REACTOR

DES:	PBAKER
DATE:	14/06/25
SCALE:	NTS

NO.	DATE	BY	REVISION

SHEET 1 OF 1

EDBCRX0075AC